 <p><b>KM size</b> KM40 = 40 mm dia. KM50 = 50 mm dia. KM63 = 63 mm dia</p>	 <p><b>Kennametal Capto size</b> C4 = 40 mm dia. C5 = 50 mm dia. C6 = 63 mm dia.</p>	 <p><b>KMXMZ size</b> KM63XMZ = 63 mm dia.</p>			
<b>1. System &amp; Size</b>			<b>4. Hand of Tool</b>	<b>5. Blade Size</b>	
<b>KM40</b>	<b>KGM</b>	<b>S</b>	<b>R</b>	<b>50</b>	
<b>2. Kennametal Grooving Modular</b>		<b>3. Tool Style</b>		<b>6. Special Conditions</b>	
		 		<p>Y = Mazak Integrex Y-series machines</p>	

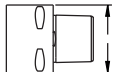

(KM-KGMSR...)

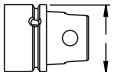
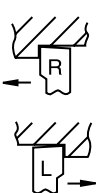
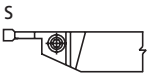
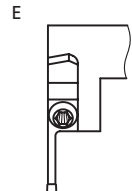

(KM-KGMEL...)